

# STOVAX

---



## *Stockton 3/4/5/6/7/8/11*

### *Free Standing Stove*

MODELS: 7118/7101/7102/7119/7160/7127/7130/7161/7100/7162/7117/7120/7163/7103/7104/  
7105/7113/7113LC/7128/7114/7106/7106LC/7106HC/7116/7116LC/7116HC

## **User Instructions**

### **For Use in Great Britain and Eire**



This product is suitable for use in the stated countries. To install the product in other countries it is essential to obtain translated instructions and in some cases the product may require modification. Contact Stovax to obtain further information.

### **IMPORTANT**

**Please read these instructions carefully before using the appliance.  
Keep them safe for future reference and when servicing the stove.**

# FOR YOUR RECORDS

To assist us in any Guarantee claim please complete the following information:-

## Stovax dealer appliance was purchased from

Name: .....

Address:.....

.....

Telephone number: .....

## Essential Information - MUST be completed

Date installed: .....

Model Description: .....

Serial number: .....

## Installation Engineer

Company name:.....

Address: .....

.....

Telephone number:.....

## Commissioning Checks (to be completed and signed)

Is flue system correct for the appliance      YES       NO

Flue swept and soundness test complete      YES       NO

Smoke test completed on installed appliance      YES       NO

Spillage test completed      YES       NO

Use of appliance and operation of controls explained      YES       NO

Instruction books handed to customer      YES       NO

Signature: .....

Print name:.....

# OPERATING INSTRUCTIONS

## 1. GENERAL

1.1 This stove is designed for domestic heating and should only be used for this purpose, and in accordance with the manufacturers operating instructions.

**It should be installed by a competent installer, in accordance with all local regulations, including those referring to national and European standards.**

- 1.2 The stove should only be used to burn approved fuels and should not be used with liquid fuels or used as an incinerator.
- 1.3 As with all heating stoves the surfaces will become very hot when in use, therefore due care should be taken when near the stove. If it is to be used in the presence of young children, elderly or infirm persons a suitable fireguard should be used. Care should also be taken with the placement of combustible items near the stove as conducted and radiated heat could cause a fire hazard.
- 1.4 Stovax offer a wide range of firescreens and sparkguards, along with a hearthgate system designed to offer full protection for a range of stoves and fireplaces. Your Stovax dealer can advise you on these products.
- 1.5 Due to the high temperature of the convected air above the stove we recommend that no valuable photographs, paintings, TV screens, porcelain or other items are placed in this area. Such artefacts may be damaged by long term exposure to fluctuating temperatures.
- 1.6 The additional ventilation required for the safe use of this stove should be kept free of any obstructions, both inside and outside the building, at all times.
- 1.7 To burn solid fuel efficiently in a wood version the multifuel kit should be fitted.

Multifuel kit part numbers:

Stove	Part No.
Stockton 5 (all)	7108
Stockton 6 (all)	7117
Stockton 7	7109
Stockton 8	7111
Stockton 8 Slimline	7111SL

Only for use with recommended fuels, see **Installation Instructions** for full fitting details.

- 1.8 Have your Stovax product serviced annually by a competent service engineer, and if repairs are required use only Stovax approved spare parts.
- 1.9 **Do not make unauthorised modifications or changes to the stove.**

1.10 **No other appliance should be connected to or share, the same flue or chimney system.**

1.11 **Do not store wood in the area beneath either the 5 Midline or 6 Highline stove.**

### SERIAL NUMBER

- 1.12 The serial number will be required when ordering spare parts or making warranty claims. It is found on the **data plate**.
- 1.13 **Stockton 3, 4, 5, 6, 7, 8, 11**  
For most Stockton models the data plate is found under the front of the stove ashlip.

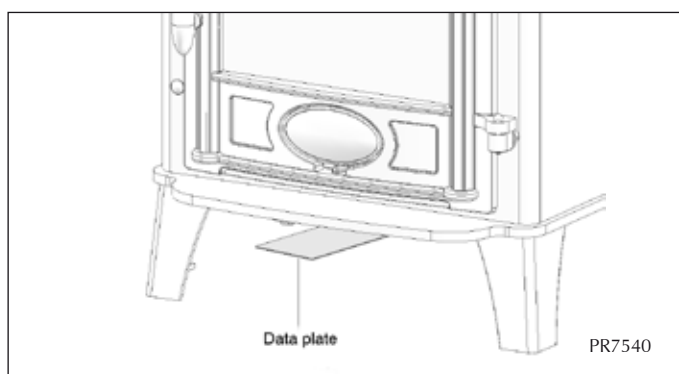

1.14 **Stockton 5 Midline**  
The data plate is found on a swing out data plate located on the back of the stove on the left hand side

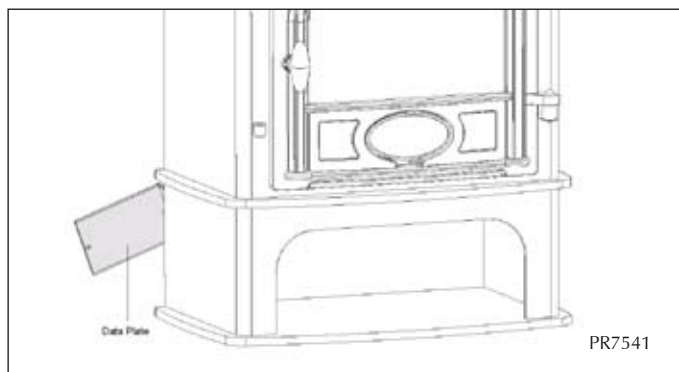

# OPERATING INSTRUCTIONS

## AIR CONTROLS

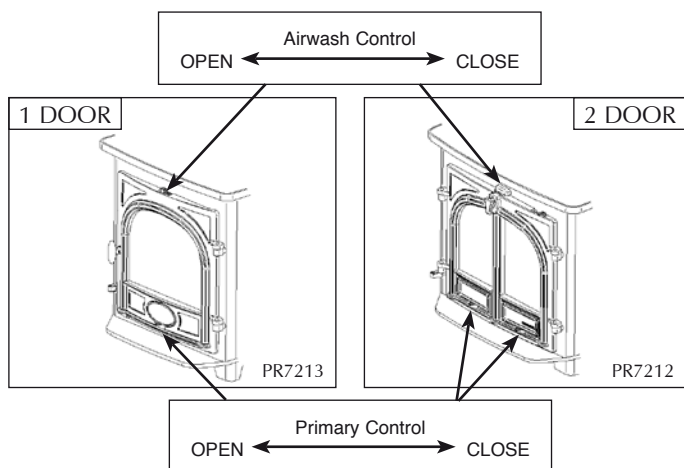

See instructions for detailed use of controls

## DOOR HANDLE

To Open and Close  
Drop tool over knob to fit. Lift and remove

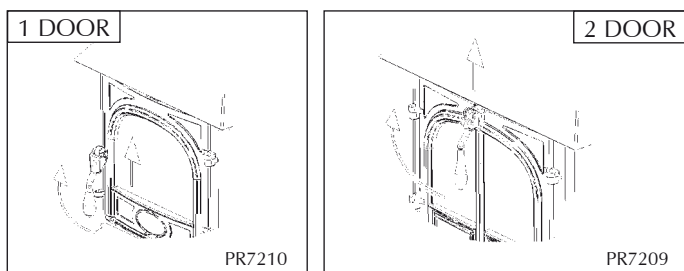

Rotate 1/4 turn clockwise to open. Rotate 1/4 turn anti-clockwise to close.

### Warning

Do not force the handle to turn more than 1/4 turn as damage may occur.

1.15 **Never open the door with your bare hands.**

1.16 Closing the door is the reverse of the previous.

## MULTI-FUEL GRATE

1.17 To de-ash the firebed, using the riddling grate system, operate by using the removable handle to pull the operating knob in and out. This causes the ash to fall down into the ashpan

1.18 **Never operate the grate with your bare hands.**

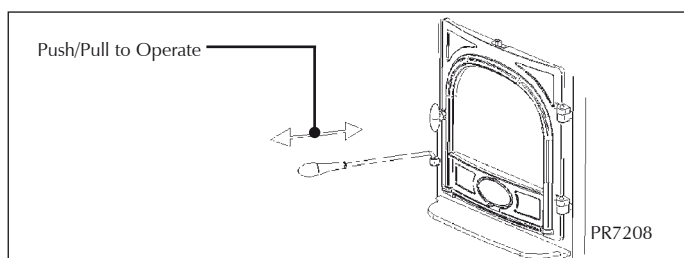

## 2. USING THE STOVE FOR THE FIRST TIME

2.1 When new, it is best to burn the fire at a low output for the first few days of use. This will allow the construction to settle and all fixing glues and paint to fully cure.

**Avoid touching the paint during the first period of use.**

2.2 During this time the stove may give off some unpleasant odours, and we recommend that you keep the room well ventilated during this period to avoid a build-up of fumes.

## 3. BURNING WOOD (with or without multifuel kit fitted)

3.1 Open the **Airwash control** fully and open the **Primary air control** to approximately 25% open.

3.2 Place some pieces of firelighter or dry crumpled paper on the grate and cover with some small pieces of dry kindling wood. Light the paper or firelighters.

3.3 To avoid the build-up of condensation on the door glass it is advisable to leave the door slightly open as the fire establishes, and the glass warms.

3.4 As the fire becomes established add larger pieces of wood and fully close the door. **Do not leave the stove with the door open as this could over-fire the stove and cause permanent damage.**

3.5 As the fire becomes established close the **Primary air control** and control the burn rate using the **Airwash control** only.

3.6 To burn wood efficiently it is best to allow a bed of ash to build-up on the grate, or the base of the stove, and control the combustion using the **Airwash control** only.

3.7 Before re-fuelling the stove it is advisable to first rake the embers evenly over the firebed then open the **Airwash control** fully for a few minutes, to establish a glowing bed before adding new logs.

3.8 Allow the new logs to burn at high output for a few minutes before adjusting the burn rate, with the **Airwash control**, to the desired setting. It is best to refuel little and often to maintain clean and efficient burning.

3.9 The ideal control settings to suit the particular installation and personal preferences will be established by experience in using the stove.

3.10 Do not load fuel higher than the log guard at the front of the stove and the secondary combustion air inlet holes at the back of the fire box.

3.11 It is not recommended to load large amounts of logs and burn with the **Airwash control** on low settings for long periods of time. This will reduce the effectiveness of the glass cleaning effect of the airwash. Also this will cause a large build-up of tars and creosotes in the stove and flue system.

# OPERATING INSTRUCTIONS

- 3.12 We would recommend that the stove be burnt at high output for at least 30 minutes each day when it is in use. This will help reduce the build-up of tars and creosotes within the stove and flue system.

## 4. BURNING SOLID FUEL (with multifuel kit fitted)

**Do not burn painted, impregnated wood or manufactured board products.**

- 4.1 Open the **Airwash control** to approximately 50% and **Primary air control** fully.
- 4.2 Place some pieces of firelighter or dry crumpled paper on the grate and cover with some small pieces of dry kindling wood. Light the paper or firelighters.
- 4.3 To avoid the build-up of condensation on the door glass it is advisable to leave the door slightly open as the fire establishes, and the glass warms.
- 4.4 As the fire becomes established add pieces of solid fuel and fully close the door. **Do not leave the stove with the door open as this could over-fire the stove and cause permanent damage.**
- 4.5 As the fire becomes established reduce the Airwash control to approximately 25% and control the burn rate using the Primary air control only.
- 4.6 To burn solid fuel efficiently it is best to control the combustion using the Primary air control only.
- 4.7 Before re-fuelling the stove it is advisable to first de-ash the firebed, using the riddling grate system. To do this open the stove door, then using the ashpan tool move the grate vigorously left to right. This causes the ash to fall down into the ashpan. Do not use bare hands to operate the riddling system.
- 4.8 Then open the **Primary air control** fully for a few minutes, to establish a glowing bed before adding new fuel. Allow the new fuel to burn at high output for a few minutes before adjusting the burn rate with the **Primary air control** to the desired setting. It is best to refuel little and often to maintain clean and efficient burning.
- 4.9 The ideal control settings to suit the particular installation and personal preferences will be established by experience in using the stove.
- 4.10 Do not load fuel higher than the log guard at the front of the stove and the secondary combustion air inlet holes at the back of the fire box.
- 4.11 We would recommend that the stove be burnt at high output for at least 30 minutes each day when it is in use. This will help reduce the build-up of tars and creosotes within the stove and flue system.

**Do not burn bituminous coal, 'petro-coke' or other petroleum based fuels, as this will invalidate any product guarantee.**

## 5. OVER-FIRING

- 5.1 Do not use the appliance at maximum output for prolonged periods of time, or over fill the firebox with fuel, as this could result in over-firing. If the connecting fluepipe, appliance flue collar or top plate glow red with heat the appliance is being over fired and the air controls should be closed to reduce the output.
- 5.2 If a chimney fire occurs shut all air controls immediately to close the appliance down, and evacuate all persons from the building before calling the fire brigade. Do not re-enter the building until it is confirmed safe to do so.
- 5.3 Following a chimney fire do not use the appliance until it is inspected by a HETAS (GB only)/ INFO (Eire) registered installer, to confirm that the appliance is safe to use, or make any repairs required before re-use. Only genuine Stovax replacement parts are to be used to keep your appliance in safe and efficient working order.
- 5.4 After any chimney fire it is recommended that the chimney system be inspected and swept by a NACS registered (UK only) chimney sweep, to confirm that the system is structurally sound and free from any obstructions before re-use.

## 6. SEASONAL USE

- 6.1 If the stove is not to be used during the warmer periods of the year it is recommended to clean and service the stove, as detailed in the Maintenance and Servicing section.
- 6.2 The air controls should be set in the 50% open position to keep the appliance ventilated, and stop the build-up of any moisture inside.
- 6.3 Before re-lighting the stove remove the baffles, clear any debris that may have accumulated, and check the flue is clear of any blockages.

## 7. ASH REMOVAL

- 7.1 The burning of any fuel will produce ash, which will have to be removed after a period of use. This time will depend on the fuel used. Before removing the ash from the stove it is advisable to let the fire burn down to a low level, or even go out completely. If a multifuel kit is fitted the ashpan can be removed from the stove using the tool provided, after opening the door.
- 7.2 As heat can remain in the ash for a long period after use, care must be taken when removing and carrying the full ashpan. We suggest that the ashpan be carried using gloved hands, or the ash is placed directly into a Stovax Ash Caddy. (Stovax Part No. 4227).
- 7.3 When burning wood the amount of ash will be smaller and may only need removal once every week. To do this, allow the fire to burn out and cool. Then after removing the log

# OPERATING INSTRUCTIONS

retainer, scoop out the ash with a suitable shovel. It is best to leave a layer of ash in the stove to form a bed for the new fire.

- 7.4 Do not place ash in a bin made from plastic or any other combustible material.

## 8. RECOMMENDED FUELS

- 8.1 **Wood:** - Burn only seasoned timber, with a moisture content of less than 20%. In most cases, this would require drying cut wood for 12 to 18 months before use. Poor quality timber could cause low combustion efficiency, produce large amounts of harmful condensation, which could reduce the effectiveness of the airwash system, and ultimately the life of the stove.

**Do not burn painted, impregnated wood or manufactured board products.**

To help avoid large build-ups of tars and creosote within the stove and the flue system, it is recommended to burn at maximum output for at least 30 minutes each day. The use of Stovax Protector chimney cleaner will also help to reduce this problem.

- 8.2 **Solid fuel:** - Burn only manufactured smokeless fuels listed as suitable for use with closed heating stoves. **Do not burn bituminous coal, 'petro-coke' or other petroleum based fuels, as this will invalidate any product guarantee.**

- 8.3 **Fuel consumption at nominal heat output.**  
As tested to the requirements of EN13240 for nominal heat output.

Description	Fuel Consumption	
	Kg/Hour Wood	Kg/Hour Briquetted Smokless Fuel
Stockton 3	1.4	0.7
Stockton 4	1.4	0.7
Stockton 5/5ML	1.5	0.7
Stockton 6/6HL	1.9	0.9
Stockton 7	2.4	1.1
Stockton 8	2.8	1.3
Stockton 11	3.5	N/A

Fuel consumption for canopy models is the same as equivalent flat top model.

## 9. BURNING PERFORMANCE

If you require advice on suitable solid fuels contact your local Approved Coal Merchant. Details can be obtained by ringing the Solid Fuel Association advice line on Freephone 0800 600 000. Or their web site at [www.solidfuel.co.uk](http://www.solidfuel.co.uk)

A number of factors can affect the performance of the Stockton stove. Some of these are listed.

### 9.1 Fuel Quality (Wood)

Use only seasoned wood with a moisture content of less than 20%. Well seasoned logs should have the bark beginning to lift and peel away, along with deep cracks radiating from the centre of the log. Logs should feel lighter than fresh cut wood of a similar size and sound hollow when struck against each other. Logs should not feel damp to the touch, have any visible moisture oozing from them or moss and fungal growths on them.

Symptoms of poor performance related to wet woods include:

- Difficulty getting a fire going and keeping it burning well,
- Smoky fires with little flame,
- Dirty glass,
- Dirty firebricks,
- Rapid creosote build-up in the chimney,
- Low heat output,
- Short burn times, excessive fuel consumption and blue/grey smoke from the chimney.

### 9.2 Fuel Quality (Solid Fuel)

Use only recommended solid fuels, which are approved for use with closed appliances. Symptoms of poor performance related to unsuitable fuels include:

- Difficulty getting a fire going and keeping it burning well,
- Smoky fires with little flame,
- Dirty glass,
- Dirty firebricks,
- Short life span for grate, baffles and internal firebricks,
- Permanent staining of glass.

### 9.3 Backpuffing

This is caused by a lack of combustion air entering the firebox causing combustion gases to build up in the firebox and periodically ignite as small explosions, causing smoke to puff out of the appliance air inlets and other openings. The problem will often occur if the air controls are shut soon after adding new fuel to a very hot fire. To stop backpuffing occurring open the air controls to increase the combustion air and increase the burning rate.

# OPERATING INSTRUCTIONS

## 9.4 Flue draught

The chimney has two main functions, which are, to safely remove the smoke, gases and fumes from the house, and to provide a sufficient amount of draught (suction) in the Stockton stove to ensure that the fire is kept burning. Draught is caused by the rising hot air in the chimney when the Stockton stove is lit.

Symptoms of poor performance related to flue draught include:

- Excessive fuel consumption (high flue draught)
- Poor burning control, overheating (high flue draught)
- Wind noise from air controls (high flue draught)
- Difficulty getting a fire going and keeping it burning well (low flue draught)
- Low heat output (low flue draught)
- Smoke entering room when doors opened (low flue draught)

The construction, position, size and height of the chimney are all factors that affect the performance of the flue draught.

Other factors that can effect the flue draught include:

- Trees or other buildings nearby causing turbulence
- High and gusty winds
- Outside temperature
- Outside weather conditions
- Incorrect additional ventilation to building
- Blocked flue / chimney

For advice on the correction of persistent flue problems consult a qualified solid fuel heating engineer before continuing to use the Stockton stove.

## 9.5 Weather conditions

The weather conditions outside the building could have an effect on the burning performance of the Stockton stove. These could include:

**Windy days** - smoking from the appliance. This could be caused by turbulent airflow around chimney terminal, possibly caused by the position of other buildings or obstacles nearby. This problem is, also, sometimes associated with oversize chimneys, which may even have downdraught problems on calm days. If smoking is a common problem on windy days make a note of the wind strength and direction before consulting your appliance installer, who will advise you on possible solutions to the problem, after visiting the installation.

**Damp / Rainy days** – These sometimes result in problems when lighting and maintaining the fire, due to the lower flue temperatures and smaller difference between indoor and outdoor temperatures reducing the flue draught. Also, rain water running down the inside of the chimney reduces the flue temperatures. To help with this problem care must

be taken to use good quality kindling wood, when starting the fire, and running the stove at a higher heat setting than normal for a period after start-up to fully heat the chimney. It could be possible to fit a rain cowl to the chimney to reduce this problem. Your appliance installer should advise you on possible solutions.

If the Stockton stove emits smoke into the room continuously close the air controls and allow the stove to go out, and ventilate the room to clear the fumes.

**Do not re-light the appliance until the cause of the problem is identified and rectified.**

## 10. TROUBLESHOOTING

### STOVE GLASS BLACKENING:

This occurs as a result of four possible causes:

- A. Burning unseasoned wood – See page 8 (section 10.1) for more information on how to identify when your wood is ready for burning. Properly seasoned logs will have been kept for a minimum of a year but are best burnt at 2 years.
- B. The stove being burned at too low a temperature - A good working temperature is 300-500° F (120 – 250° C). A stove pipe thermometer will help identify this problem. (Stovax part no 3046). Burning the stove with the airwash control fully open for a period of around 20 minutes ought to cure this. This might be caused by damping your stove down overnight.
- C. Problems with your flue – in particular insufficient air pull. If your flue is not doing its job efficiently this can cause blackening of the glass. A flue which is too short, experiences a downdraft, needs lining or has too many bends can promote blackening. If you suspect your flue may be contributing to the blackening of your stove glass you should contact the installer or a flue specialist.

### RIDDLING MECHANISM JAMMING:

This occurs when fine ash builds up under the riddling mechanism preventing their movement. To prevent this we recommend that you follow a regular cleaning routine for the inside of your stove, taking care to lift out the riddling mechanism and remove all ash. Replace riddling grate when cleaning is complete.

### STOVE GLASS CRACKING:

Please ensure when replacing the glass in your stove that you do not over tighten the screws on the glass clips as this will cause stress in the glass and with the intense heating and cooling of burning your stove it may well cause the glass to crack.

# OPERATING INSTRUCTIONS

## STOVE IS PRODUCING TAR:

You can recognise this from the following traits:  
Very strong pungent smell shortly after the stove is lit and as the stove heats up, glass blackening and, possibly, can be seen as a thick, brown and sticky material oozing from your stove pipe joints.

This is caused by burning damp wood and burning your stove at too low a temperature. To resolve this only use well seasoned wood and ensure your stove is operating in the ideal temperature range. Tar is a major cause of chimney fires - if you experience problems with tar build up, please consult a chimney sweep before continued use of your stove.

**Ideal working temperature** range is 130°C and 240°C (270°F – 465°F). If you fail to close down your primary air control once the stove has heated up to this range you may cause your stove to overfire and the temperature to exceed the ideal range. Overfiring can cause permanent damage to your stove and will invalidate your warranty.

## HINGE PIN RIDING UP:

This occurs when the hinge block has moved out of alignment. To correct this adjust the hinge blocks back to the vertical position. See section 10 page 12 for information on adjusting the door hinges.



# MAINTENANCE and SERVICING

See chart on page 10 for common spare parts referred to in this section.  
For a complete list of spare parts and accessories contact your Stovax dealer for the Stovax Fireplace, Stove & Hearth Accessories brochure or call 01392 474011

## 1. GENERAL CLEANING

**Before any cleaning is carried out, allow stove to cool thoroughly to avoid risk of burns.**

- 1.1 We would recommend that your Stockton stove be cleaned fully on a regular basis, according to the level of use. Attention should be given to cleaning the baffle system, flueways and removing ash. Regular cleaning and preventive maintenance will help give many years of safe use.
- 1.2 The external paintwork may be cleaned using warm soapy water and a soft clean cloth. Wipe dry with a soft clean cloth before re-lighting. Do not leave unit without drying, as this may cause rust.

## 2. CLEANING GLASS

- 2.1 While the correct use of the Airwash system, and good quality fuel, will generally keep the glass clean when the appliance is used you may sometimes need to clean the glass.
- 2.2 This can be done as follows. Allow the Stockton stove to cool fully, never attempt to clean hot glass. Any deposits can be removed using a soft cloth and Stovax Glass Cleaner.
- 2.3 Before re-lighting the appliance, dry the glass fully.
- 2.4 **Do not use abrasive cleaner or cleaning pads.**

## 3. CHIMNEY SWEEPING

- 3.1 We would recommend that to maintain the safe and efficient use of the appliance the flue / chimney is inspected and swept at least **once a year, by a NACS Registered (UK only) / INFO Registered (Eire only) chimney sweep, who will issue you with a certificate.**

## 4. ANNUAL SERVICE

At the end of the heating season it is recommended to strip, inspect and clean the stove as detailed: -

- 4.1 Carefully remove all of the following internal parts. 2 internal baffles, firebricks, complete grate (2 parts), and ashpan. See sections 6 and 7 for the instructions on how to remove the baffles and firebricks. Care should be taken when handling firebricks, as they can become fragile after a period of use.

- 4.2 Vacuum clean any remaining ash and debris from the inside of the stove. Stovax offer a filter / collection attachment for your vacuum cleaner to protect it from fine ash. Ash clean (Stovax Part No. 2091).
- 4.3 Clean the internal surfaces of the stove using a wire brush and scraper as required. Vacuum and brush the resulting debris from the stove.
- 4.4 Clean the baffle and grate parts with a wire brush, and check the parts for any damage. Replace any damaged parts.
- 4.5 Check and clean the firebricks with a soft brush. Replace any broken bricks. It is normal for some surface damage to occur during use.
- 4.6 Re-fit cleaned internal parts.
- 4.7 Remove the glass from the door, see section 8, and discard all old rope seals.
- 4.8 Remove the door rope seal from the outer edge of the door and clean the old glue from the door sealing rope groove.
- 4.9 Clean the door glass using Stovax Stove Glass Cleaner and a soft cloth, do not use abrasive cleaners to remove tar or soot deposits from the glass.
- 4.10 Replace the glass edge seal with new and re-fit the glass into place in the door. (See section 8, page 11).
- 4.11 Fit new door rope seal with the joint in the middle of the lower edge of the door, gluing it in place with Stovax Thermic Seal rope adhesive (See section 9, page 12). When fitting new door seals we recommend closing the stove door and leaving for at least 12 hours before using. This allows the adhesive to fully bond to the seal before use.
- 4.12 Lightly oil the door catch mechanism and hinge pins. Avoid getting oil onto the door seals and glass.
- 4.13 To refresh painted finishes it is possible to re-paint using Stovax Thermolac stove paint.
- 4.14 We recommend that only genuine Stovax replacement parts are used to keep your appliance in safe and efficient working order. Your local Stovax dealer will be able to provide you with the genuine parts you require.

# MAINTENANCE and SERVICING

4.15 This is a list of the maintenance products you may need to use

Task	Product name	Stovax Code Number
Glass cleaning	Stove glass cleaner 500ml (wipe on)	4111
	Stove glass cleaner (spray on)	4130
Preventing build-up of creosote in flue	Protector (15 sachets)	7002
	Protector (1kg tub)	7025
Sealing flue pipe joints	Fire Cement (500g tub)	2020
	Fire Cement (600g cartridge)	2021
Re-painting	Thermolac Black (400ml aerosol)	2019
	Thermolac Black (9200ml brush-on)	2057
Cleaning matt black stoves	Colloidal black (85ml)	7000
Protecting your hands	Heat resistant leather gloves	4008
Door sealing rope	14mm Black rope seal (handy pack)	5000
	14mm Black rope seal (25m reel)	4670
Glass sealing tape	3mm Black rope seal (handy pack)	4975
	3mm Black rope seal (25m reel)	4974
Fixing rope seal	Thermic seal glue (50ml bottle)	5037
Ash Clean	Vacuum Cleaner Attachment	2091

4.16 These products, all available from your local Stovax dealer, along with regular maintenance and use of correct fuels, will help you to keep your stove in the best condition.

4.17 If you require more information about Stovax group products, visit our website [www.stovax.com](http://www.stovax.com).

4.18 When using the stove for the first time again it is best to burn the fire at a low output for the first day of use. This will allow the new seals to settle and all new fixing glues and paint to fully cure.

4.19 During this time, the stove may give off some unpleasant odours, and we recommend that you keep the room well ventilated during this period to avoid a build-up of fumes.

4.20 If you require help, your local Stovax dealer will be able to carry out all of your service and maintenance requirements for a reasonable cost.

## 5. REMOVAL OF THE LOG GUARD

5.1 Remove the log guard by lifting clear of the supporting brackets and rotating to clear the sides of the door opening. The stove should not be used without the log guard in position.

## 6. FITTING AND REMOVAL OF BAFFLE

6.1 To maintain efficient combustion the stove is fitted with a baffle in the top of the firebox.

6.2 Allow the stove to cool fully before removing the baffle system.

6.3 To remove the baffle, first remove the log guard from the stove to give access to the firebox.

6.4 Remove the baffle by lifting the front edge to clear the support bars, then pull the baffle forward to disengage the rear edge from the location above air inlet holes. Rotate the baffle to remove from the firebox through the door opening.

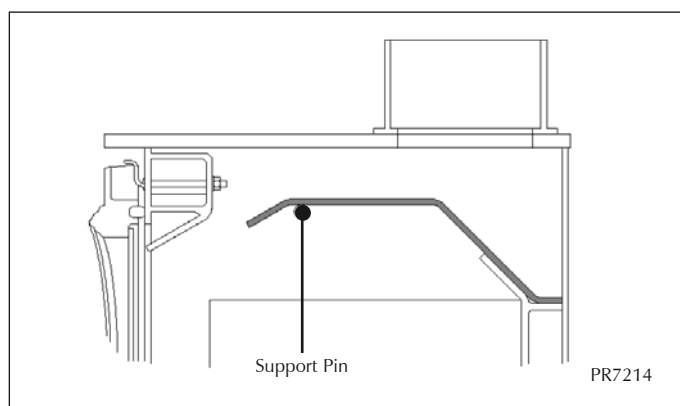

6.5 The replacement of the system is the reverse of the previous operations, ensuring it is replaced the correct way around.

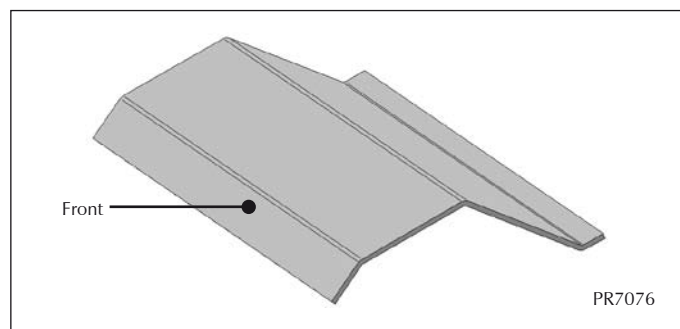

# MAINTENANCE and SERVICING

- 6.6 It is important to remove and clean the baffle system to ensure the flue ways are clear of soot and debris and to ensure the safe and efficient operation of the stove. The frequency of cleaning will depend on the stove operating conditions.
- 6.7 The baffle system is designed to give safe and efficient operation of the stove. Replace any damaged baffles immediately.
- 6.8 Do not modify the baffle system.

## 7. FITTING & REMOVAL OF FIREBRICKS

- 7.1 As part of the routine maintenance of the stove you may have to remove the firebricks from the stove. This can be carried-out without the use of tools, but the bricks must be removed and replaced as shown, after removing the baffle system.
- 7.2 Allow the stove to cool fully before removing firebricks.
- 7.3 If your stove is fitted with 4 upper firebricks, remove the lower 2 bricks first. Then lower the top bricks and remove.

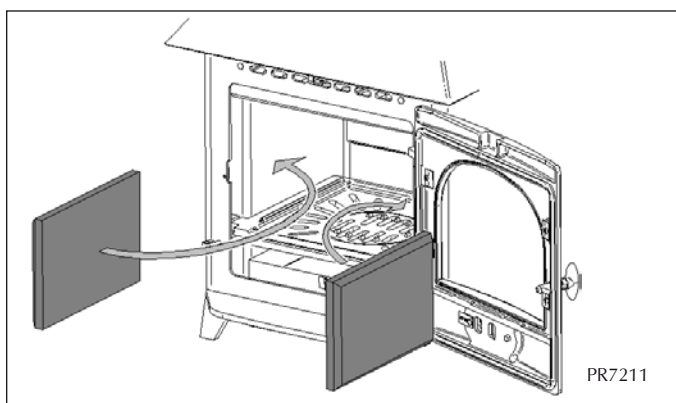

- 7.4 Replace the bricks in the reverse order of removal.
- 7.5 Care should be taken when handling bricks, as they can become fragile after a period of use. This is normal and the life will depend on the type of fuels burnt and the level of use. Damaged bricks should be replaced as soon as possible, and can be purchased from your Stovax dealer.

## 8. FITTING A NEW DOOR GLASS

- 8.1 To maintain the safe use of your stove you may need to replace a damaged door glass. To complete this operation, use this method.
- 8.2 Remove the door, by opening and lifting the door free of the hinge blocks. Then lie the door face down on a soft flat surface, to protect the paintwork and glass.

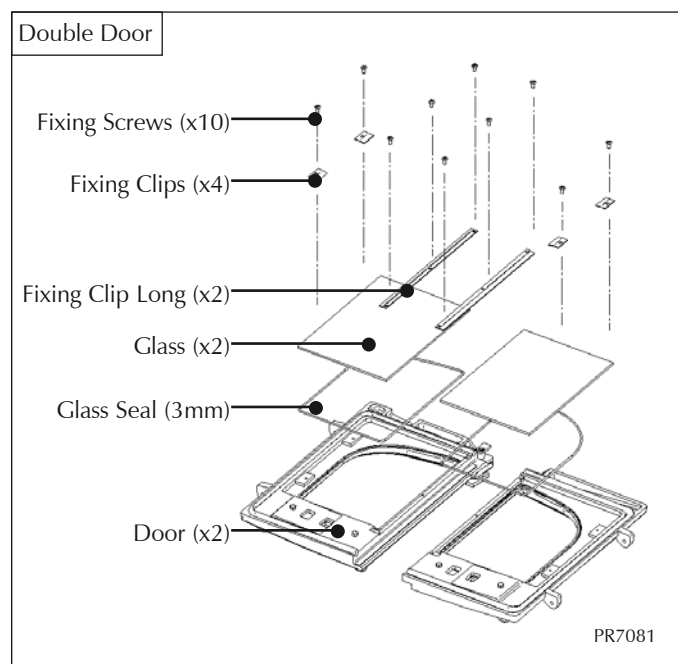
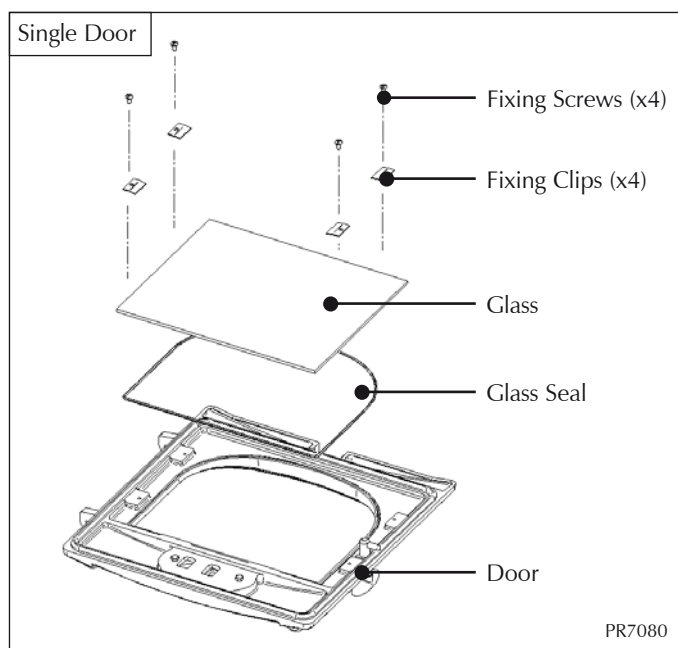

- 8.3 Using a screwdriver remove the glass clip fixing screws (4). The old glass can then be lifted clear of the door. (Note how the 3mm sealing rope is placed between the glass and the door.) Remember to dispose of the old glass safely.
- 8.4 Clean, and re-paint, the rear of the door if required. Clean the screws with light oil and coat with high temperature anti-seize grease, this will aid future removal.
- 8.5 Fit a new sealing rope between the new glass and the door, and place the glass into position in the door. Place the glass fixing clips into position and re-fix with the clean fixing screws, tighten the screws evenly until the clips hold the glass. Do not over tighten the clips as this could break the glass.

# MAINTENANCE and SERVICING

- 8.6 Fit only Stovax ceramic glass, which is suitable to use in high temperature applications.
- 8.7 Using the stove with a damaged door glass could cause dangerous fumes to enter the room, or the stove to overfire, resulting in damage.

## 9. FITTING A NEW DOOR SEAL

- 9.1 To maintain the safe use of your stove you may need to replace a damaged or worn door sealing rope. To complete this operation, use this method.
- 9.2 Remove the door from the stove, by opening and lifting the door free of the hinge blocks. Then lie the door face down on a soft flat surface, to protect the paintwork and glass.

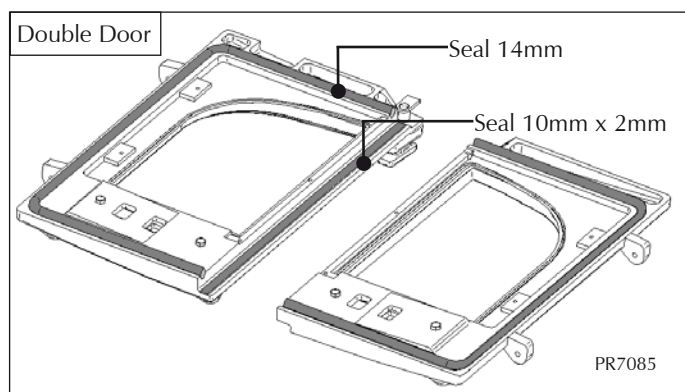
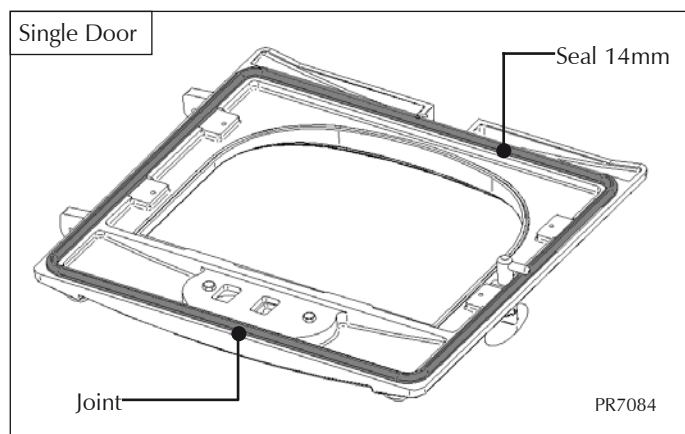

- 9.3 Remove the old rope and scrape old glue from the locating groove. Clean the locating groove with a clean dry cloth to remove all old dust and debris.
- 9.4 Squeeze a generous bead of fresh Stovax Thermic Seal glue (Stovax Part No. 5037) into the rope locating groove. Press the new Stovax rope into the locating groove, placing the joint in the middle of the lower edge of the door.
- 9.5 Refit the door and close the door to apply pressure to new rope. Leave the stove closed for at least 12 hours before lighting the stove and using at a low output for approximately one day.

- 9.6 Using the stove with a damaged door seal could cause dangerous fumes to enter the room, or the stove to overfire, resulting in damage.

## 10. ADJUSTING DOOR HINGES

- 10.1 To maintain the safe use of your Stockton stove, you may need to adjust the door hinges to ensure safe correct closing of the door. Complete this operation as follows.
- 10.2 Open the door to give access to the fixed part of the door hinge as shown.

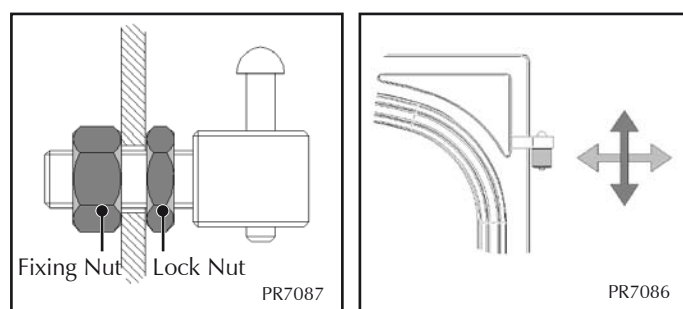

- 10.3 Using a 19mm A/F spanner loosen the fixing nuts, as shown, and reposition the hinge blocks to achieve a correct fit. This may require a trial and error approach to find the correct position.

# EC Declaration of Conformity



The undersigned, representing the following :

Manufacturer
<b>Stovax Ltd</b> Falcon Road, Sowton Industrial Estate Exeter EX2 7LF

Herewith declare that the products :

Description	Product code
Stockton 3 m/f	7118
Stockton 4 wood	7101
Stockton 4 m/f	7102
Stockton 5 wood	7119 / 7160
Stockton 5 m/f	7127 / 7161
Stockton 5 Midline	7130
Stockton 6 wood	7100
Stockton 6 m/f	7162
Stockton 6 Highline	7117

Description	Product code
Stockton 7 wood	7120
Stockton 7 m/f	7163
Stockton 8 wood – 1 door	7103 / 7104 / 7105
Stockton 8 wood – 2 door	7113 / 7113LC / 7113HC
Stockton 8 Slimline	7114
Stockton 8 m/f	7128
Stockton 11 wood – 1 door	7106 / 7106LC / 7106HC
Stockton 11 wood – 2 door	7116 / 7116LC / 7116HC

Description of product : Stockton domestic wood and multifuel heating stove product range

Steel fabricated stove body fitted with cast iron door sets, various canopy and firegrate options. Supplied in various sizes to give a range of heat output options.

are in conformity with the provisions of the following EC Directive(s) when installed in accordance with the installation instructions in the product documentation :

98/106/EEC Construction Products Directive

and the standards referenced below have been applied :

EN 13240 : 2001 Roomheaters fired by solid fuel – Requirements and test methods

Provisions to which the product conforms :

Product : Roomheater fired by solid fuel as covered under the scope of the standards listed. Intended use : Space heating in residential buildings.		
Characteristic	Performance	Report
Fire safety	Satisfies	
Emission of combustion products	Stockton 3 (7118) CO @ 13% O <sub>2</sub> Wood 0.27% - Briquetted fuel 0.20%	2005 PMC / 173
	Stockton 4 ( 7101 / 7102) CO @ 13% O <sub>2</sub> Wood 0.27% - Briquetted fuel 0.28%	2005 PMC / 174
	Stockton 5 (7119 / 7160 / 7127 / 7130 / 7161) CO @ 13% O <sub>2</sub> Wood 0.22% - Briquetted fuel 0.29%	2005 PMC / 175
	Stockton 6 (7100 / 7162 / 7117) CO @ 13% O <sub>2</sub> Wood 0.20% - Briquetted fuel 0.48%	2005 PMC / 176
	Stockton 7 (7120 / 7163) CO @ 13% O <sub>2</sub> Wood 0.20% - Briquetted fuel 0.47%	2005 PMC / 177
	Stockton 8 (7103 / 7104 / 7105 / 7113 / 7113LC / 7113HC / 7128) CO @ 13% O <sub>2</sub> Wood 0.08% - Briquetted fuel 0.25%	2005 PMC / 179
	Stockton 8sl (7114) CO @ 13% O <sub>2</sub> Wood 0.25% - Briquetted fuel 0.47%	2005 PMC / 178
	Stockton 11 (7106 / 7106LC / 7106HC / 7116 / 7116LC / 7116HC) CO @ 13% O <sub>2</sub> Wood 0.07%	2005 PMC / 180
Release of dangerous substance	None	
Surface temperature	Satisfies	
Mechanical resistance (to carry a chimney/flue)	Maximum weight to be supported 25Kg	
Thermal output / Efficiency	Stockton 3 (7118) Wood 3.75Kw @ 77% - Briquetted fuel 3.75Kw @ 86%	2005 PMC / 173
	Stockton 4 ( 7101 / 7102) Wood 4.00Kw @ 77% - Briquetted fuel 4.00Kw @ 85%	2005 PMC / 174
	Stockton 5 (7119 / 7160 / 7127 / 7130 / 7161) Wood 5.00Kw @ 80% - Briquetted fuel 5.00Kw @ 85%	2005 PMC / 175
	Stockton 6 (7100 / 7162 / 7117) Wood 6.00Kw @ 79% - Briquetted fuel 6.00Kw @ 80%	2005 PMC / 176
	Stockton 7 (7120 / 7163) Wood 7.00Kw @ 77% - Briquetted fuel 7.00Kw @ 80%	2005 PMC / 177
	Stockton 8 (7103 / 7104 / 7105 / 7113 / 7113LC / 7113HC / 7128) Wood 8.00Kw @ 76% - Briquetted fuel 8.00Kw @ 81%	2005 PMC / 179
	Stockton 8sl (7114) Wood 7.00Kw @ 78% - Briquetted fuel 7.00Kw @ 81%	2005 PMC / 178
	Stockton 11 (7106 / 7106LC / 7106HC / 7116 / 7116LC / 7116HC) Wood 11.00Kw @ 76%	2005 PMC / 180

Test laboratory : 1641

Name : D. J. Saunders

Signature :

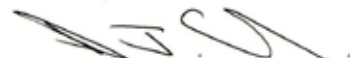

Position : Design Engineer

Date : 02 / 04 / 2007

Sheet 2 of 2

# CARE OF YOUR STOCKTON

To help you get the best performance from your Stockton and keep it in good condition, inside and out, Stovax offers a wide range of cleaning and maintenance products as well as a host of accessories to help you enjoy the maximum pleasure from your stove. Your Stovax retailer will be able to provide full details but here is a brief list of items that may be of interest:

Product Code	Description
3047	Extra long matches
5039	Gas lighter
4052	Log basket
3048	Wood sling - for easy carrying of logs
3016	Log tongs
4027	Extra long protective gloves
3046	Stove pipe thermometer
5038	Hearthgate - 5 section (for areas 1780x610mm)
5044	Hearthgate - 7 section (for areas 1780x405mm)
4227	Ash caddy - All models except Stockton 11MF
4228	Ash caddy - Stockton 11MF only
2091	Ashclean vacuum cleaner attachment
4232	Steel brush



Your retailer will also be able to provide genuine spare parts such as replacement glass, door sealing rope and fire bricks, as and when required. Remember, an annual service is recommended to keep your appliance in best possible condition.

# STOVAX

Stovax Ltd, Falcon Road, Sowton Industrial Estate, Exeter, Devon, England EX2 7LF  
Tel: (01392) 474011 Fax: (01392) 219932 E-mail: [info@stovax.com](mailto:info@stovax.com) [www.stovax.com](http://www.stovax.com)